



**FRAME ANY SPACE IN A FLASH.**



**TELESCOPIC  
INTERIOR WALL  
PANELS DESIGNED**

User guide for  
installation of  
designed telescopic  
wall panels



# Telescopic Panels - Designed

Telescopic Panels for commercial interior framing, manufactured to your supplied designed files, cut the need for constant measuring cut the need for constant measuring and remeasuring, snipping, and adjusting onsite. Any doors and windows within the panels are fixed to remain perfectly square at all times. That means you save time, effort and reduce wastage too. And they make levelling up soffit panels a breeze.

Telescopic panels with two-axis or multi-axis extensions are pre-assembled and compressed for delivery or flat packed. Frames are strong, lightweight, and retractable, so they are easy to move around onsite, even in tight spaces. Then expand and secure for a fitting end, every time.



**APARTMENT  
15/09**



**Rollforming  
SERVICES LIMITED**

Generated with FrameBuilder-MRD Light Steel Designer, V5.1.3

Drawing	Alt - 1	Distance from Ground	0.0 mm	Height	2650.0 mm	Length	~ 3043.9 mm	Screws	62																																																																																																																																																																																																																																																																																																																																																																																										
<table border="1" style="width: 100%; border-collapse: collapse; font-size: 6px;"> <thead> <tr> <th>Item No.</th> <th>Part No.</th> <th>Part Name</th> <th>Quantity</th> <th>Unit</th> <th>Length</th> </tr> </thead> <tbody> <tr><td>1</td><td>2221-10</td><td>Upright</td><td>1</td><td>mm</td><td>2650.0</td></tr> <tr><td>2</td><td>2221-11</td><td>Upright</td><td>1</td><td>mm</td><td>2650.0</td></tr> <tr><td>3</td><td>2221-12</td><td>Upright</td><td>1</td><td>mm</td><td>2650.0</td></tr> <tr><td>4</td><td>2221-13</td><td>Upright</td><td>1</td><td>mm</td><td>2650.0</td></tr> <tr><td>5</td><td>2221-14</td><td>Upright</td><td>1</td><td>mm</td><td>2650.0</td></tr> <tr><td>6</td><td>2221-15</td><td>Upright</td><td>1</td><td>mm</td><td>2650.0</td></tr> <tr><td>7</td><td>2221-16</td><td>Upright</td><td>1</td><td>mm</td><td>2650.0</td></tr> <tr><td>8</td><td>2221-17</td><td>Upright</td><td>1</td><td>mm</td><td>2650.0</td></tr> <tr><td>9</td><td>2221-18</td><td>Upright</td><td>1</td><td>mm</td><td>2650.0</td></tr> <tr><td>10</td><td>2221-19</td><td>Upright</td><td>1</td><td>mm</td><td>2650.0</td></tr> <tr><td>11</td><td>2221-20</td><td>Upright</td><td>1</td><td>mm</td><td>2650.0</td></tr> <tr><td>12</td><td>2221-21</td><td>Upright</td><td>1</td><td>mm</td><td>2650.0</td></tr> <tr><td>13</td><td>2221-22</td><td>Upright</td><td>1</td><td>mm</td><td>2650.0</td></tr> <tr><td>14</td><td>2221-23</td><td>Upright</td><td>1</td><td>mm</td><td>2650.0</td></tr> <tr><td>15</td><td>2221-24</td><td>Upright</td><td>1</td><td>mm</td><td>2650.0</td></tr> <tr><td>16</td><td>2221-25</td><td>Upright</td><td>1</td><td>mm</td><td>2650.0</td></tr> <tr><td>17</td><td>2221-26</td><td>Upright</td><td>1</td><td>mm</td><td>2650.0</td></tr> <tr><td>18</td><td>2221-27</td><td>Upright</td><td>1</td><td>mm</td><td>2650.0</td></tr> <tr><td>19</td><td>2221-28</td><td>Upright</td><td>1</td><td>mm</td><td>2650.0</td></tr> <tr><td>20</td><td>2221-29</td><td>Upright</td><td>1</td><td>mm</td><td>2650.0</td></tr> <tr><td>21</td><td>2221-30</td><td>Upright</td><td>1</td><td>mm</td><td>2650.0</td></tr> <tr><td>22</td><td>2221-31</td><td>Upright</td><td>1</td><td>mm</td><td>2650.0</td></tr> <tr><td>23</td><td>2221-32</td><td>Upright</td><td>1</td><td>mm</td><td>2650.0</td></tr> <tr><td>24</td><td>2221-33</td><td>Upright</td><td>1</td><td>mm</td><td>2650.0</td></tr> <tr><td>25</td><td>2221-34</td><td>Upright</td><td>1</td><td>mm</td><td>2650.0</td></tr> <tr><td>26</td><td>2221-35</td><td>Upright</td><td>1</td><td>mm</td><td>2650.0</td></tr> <tr><td>27</td><td>2221-36</td><td>Upright</td><td>1</td><td>mm</td><td>2650.0</td></tr> <tr><td>28</td><td>2221-37</td><td>Upright</td><td>1</td><td>mm</td><td>2650.0</td></tr> <tr><td>29</td><td>2221-38</td><td>Upright</td><td>1</td><td>mm</td><td>2650.0</td></tr> <tr><td>30</td><td>2221-39</td><td>Upright</td><td>1</td><td>mm</td><td>2650.0</td></tr> <tr><td>31</td><td>2221-40</td><td>Upright</td><td>1</td><td>mm</td><td>2650.0</td></tr> <tr><td>32</td><td>2221-41</td><td>Upright</td><td>1</td><td>mm</td><td>2650.0</td></tr> <tr><td>33</td><td>2221-42</td><td>Upright</td><td>1</td><td>mm</td><td>2650.0</td></tr> <tr><td>34</td><td>2221-43</td><td>Upright</td><td>1</td><td>mm</td><td>2650.0</td></tr> <tr><td>35</td><td>2221-44</td><td>Upright</td><td>1</td><td>mm</td><td>2650.0</td></tr> <tr><td>36</td><td>2221-45</td><td>Upright</td><td>1</td><td>mm</td><td>2650.0</td></tr> <tr><td>37</td><td>2221-46</td><td>Upright</td><td>1</td><td>mm</td><td>2650.0</td></tr> <tr><td>38</td><td>2221-47</td><td>Upright</td><td>1</td><td>mm</td><td>2650.0</td></tr> <tr><td>39</td><td>2221-48</td><td>Upright</td><td>1</td><td>mm</td><td>2650.0</td></tr> <tr><td>40</td><td>2221-49</td><td>Upright</td><td>1</td><td>mm</td><td>2650.0</td></tr> <tr><td>41</td><td>2221-50</td><td>Upright</td><td>1</td><td>mm</td><td>2650.0</td></tr> <tr><td>42</td><td>2221-51</td><td>Upright</td><td>1</td><td>mm</td><td>2650.0</td></tr> <tr><td>43</td><td>2221-52</td><td>Upright</td><td>1</td><td>mm</td><td>2650.0</td></tr> <tr><td>44</td><td>2221-53</td><td>Upright</td><td>1</td><td>mm</td><td>2650.0</td></tr> <tr><td>45</td><td>2221-54</td><td>Upright</td><td>1</td><td>mm</td><td>2650.0</td></tr> <tr><td>46</td><td>2221-55</td><td>Upright</td><td>1</td><td>mm</td><td>2650.0</td></tr> <tr><td>47</td><td>2221-56</td><td>Upright</td><td>1</td><td>mm</td><td>2650.0</td></tr> <tr><td>48</td><td>2221-57</td><td>Upright</td><td>1</td><td>mm</td><td>2650.0</td></tr> <tr><td>49</td><td>2221-58</td><td>Upright</td><td>1</td><td>mm</td><td>2650.0</td></tr> <tr><td>50</td><td>2221-59</td><td>Upright</td><td>1</td><td>mm</td><td>2650.0</td></tr> <tr><td>51</td><td>2221-60</td><td>Upright</td><td>1</td><td>mm</td><td>2650.0</td></tr> <tr><td>52</td><td>2221-61</td><td>Upright</td><td>1</td><td>mm</td><td>2650.0</td></tr> <tr><td>53</td><td>2221-62</td><td>Upright</td><td>1</td><td>mm</td><td>2650.0</td></tr> <tr><td>54</td><td>2221-63</td><td>Upright</td><td>1</td><td>mm</td><td>2650.0</td></tr> <tr><td>55</td><td>2221-64</td><td>Upright</td><td>1</td><td>mm</td><td>2650.0</td></tr> <tr><td>56</td><td>2221-65</td><td>Upright</td><td>1</td><td>mm</td><td>2650.0</td></tr> <tr><td>57</td><td>2221-66</td><td>Upright</td><td>1</td><td>mm</td><td>2650.0</td></tr> <tr><td>58</td><td>2221-67</td><td>Upright</td><td>1</td><td>mm</td><td>2650.0</td></tr> <tr><td>59</td><td>2221-68</td><td>Upright</td><td>1</td><td>mm</td><td>2650.0</td></tr> <tr><td>60</td><td>2221-69</td><td>Upright</td><td>1</td><td>mm</td><td>2650.0</td></tr> <tr><td>61</td><td>2221-70</td><td>Upright</td><td>1</td><td>mm</td><td>2650.0</td></tr> <tr><td>62</td><td>2221-71</td><td>Upright</td><td>1</td><td>mm</td><td>2650.0</td></tr> </tbody> </table>										Item No.	Part No.	Part Name	Quantity	Unit	Length	1	2221-10	Upright	1	mm	2650.0	2	2221-11	Upright	1	mm	2650.0	3	2221-12	Upright	1	mm	2650.0	4	2221-13	Upright	1	mm	2650.0	5	2221-14	Upright	1	mm	2650.0	6	2221-15	Upright	1	mm	2650.0	7	2221-16	Upright	1	mm	2650.0	8	2221-17	Upright	1	mm	2650.0	9	2221-18	Upright	1	mm	2650.0	10	2221-19	Upright	1	mm	2650.0	11	2221-20	Upright	1	mm	2650.0	12	2221-21	Upright	1	mm	2650.0	13	2221-22	Upright	1	mm	2650.0	14	2221-23	Upright	1	mm	2650.0	15	2221-24	Upright	1	mm	2650.0	16	2221-25	Upright	1	mm	2650.0	17	2221-26	Upright	1	mm	2650.0	18	2221-27	Upright	1	mm	2650.0	19	2221-28	Upright	1	mm	2650.0	20	2221-29	Upright	1	mm	2650.0	21	2221-30	Upright	1	mm	2650.0	22	2221-31	Upright	1	mm	2650.0	23	2221-32	Upright	1	mm	2650.0	24	2221-33	Upright	1	mm	2650.0	25	2221-34	Upright	1	mm	2650.0	26	2221-35	Upright	1	mm	2650.0	27	2221-36	Upright	1	mm	2650.0	28	2221-37	Upright	1	mm	2650.0	29	2221-38	Upright	1	mm	2650.0	30	2221-39	Upright	1	mm	2650.0	31	2221-40	Upright	1	mm	2650.0	32	2221-41	Upright	1	mm	2650.0	33	2221-42	Upright	1	mm	2650.0	34	2221-43	Upright	1	mm	2650.0	35	2221-44	Upright	1	mm	2650.0	36	2221-45	Upright	1	mm	2650.0	37	2221-46	Upright	1	mm	2650.0	38	2221-47	Upright	1	mm	2650.0	39	2221-48	Upright	1	mm	2650.0	40	2221-49	Upright	1	mm	2650.0	41	2221-50	Upright	1	mm	2650.0	42	2221-51	Upright	1	mm	2650.0	43	2221-52	Upright	1	mm	2650.0	44	2221-53	Upright	1	mm	2650.0	45	2221-54	Upright	1	mm	2650.0	46	2221-55	Upright	1	mm	2650.0	47	2221-56	Upright	1	mm	2650.0	48	2221-57	Upright	1	mm	2650.0	49	2221-58	Upright	1	mm	2650.0	50	2221-59	Upright	1	mm	2650.0	51	2221-60	Upright	1	mm	2650.0	52	2221-61	Upright	1	mm	2650.0	53	2221-62	Upright	1	mm	2650.0	54	2221-63	Upright	1	mm	2650.0	55	2221-64	Upright	1	mm	2650.0	56	2221-65	Upright	1	mm	2650.0	57	2221-66	Upright	1	mm	2650.0	58	2221-67	Upright	1	mm	2650.0	59	2221-68	Upright	1	mm	2650.0	60	2221-69	Upright	1	mm	2650.0	61	2221-70	Upright	1	mm	2650.0	62	2221-71	Upright	1	mm	2650.0
Item No.	Part No.	Part Name	Quantity	Unit	Length																																																																																																																																																																																																																																																																																																																																																																																														
1	2221-10	Upright	1	mm	2650.0																																																																																																																																																																																																																																																																																																																																																																																														
2	2221-11	Upright	1	mm	2650.0																																																																																																																																																																																																																																																																																																																																																																																														
3	2221-12	Upright	1	mm	2650.0																																																																																																																																																																																																																																																																																																																																																																																														
4	2221-13	Upright	1	mm	2650.0																																																																																																																																																																																																																																																																																																																																																																																														
5	2221-14	Upright	1	mm	2650.0																																																																																																																																																																																																																																																																																																																																																																																														
6	2221-15	Upright	1	mm	2650.0																																																																																																																																																																																																																																																																																																																																																																																														
7	2221-16	Upright	1	mm	2650.0																																																																																																																																																																																																																																																																																																																																																																																														
8	2221-17	Upright	1	mm	2650.0																																																																																																																																																																																																																																																																																																																																																																																														
9	2221-18	Upright	1	mm	2650.0																																																																																																																																																																																																																																																																																																																																																																																														
10	2221-19	Upright	1	mm	2650.0																																																																																																																																																																																																																																																																																																																																																																																														
11	2221-20	Upright	1	mm	2650.0																																																																																																																																																																																																																																																																																																																																																																																														
12	2221-21	Upright	1	mm	2650.0																																																																																																																																																																																																																																																																																																																																																																																														
13	2221-22	Upright	1	mm	2650.0																																																																																																																																																																																																																																																																																																																																																																																														
14	2221-23	Upright	1	mm	2650.0																																																																																																																																																																																																																																																																																																																																																																																														
15	2221-24	Upright	1	mm	2650.0																																																																																																																																																																																																																																																																																																																																																																																														
16	2221-25	Upright	1	mm	2650.0																																																																																																																																																																																																																																																																																																																																																																																														
17	2221-26	Upright	1	mm	2650.0																																																																																																																																																																																																																																																																																																																																																																																														
18	2221-27	Upright	1	mm	2650.0																																																																																																																																																																																																																																																																																																																																																																																														
19	2221-28	Upright	1	mm	2650.0																																																																																																																																																																																																																																																																																																																																																																																														
20	2221-29	Upright	1	mm	2650.0																																																																																																																																																																																																																																																																																																																																																																																														
21	2221-30	Upright	1	mm	2650.0																																																																																																																																																																																																																																																																																																																																																																																														
22	2221-31	Upright	1	mm	2650.0																																																																																																																																																																																																																																																																																																																																																																																														
23	2221-32	Upright	1	mm	2650.0																																																																																																																																																																																																																																																																																																																																																																																														
24	2221-33	Upright	1	mm	2650.0																																																																																																																																																																																																																																																																																																																																																																																														
25	2221-34	Upright	1	mm	2650.0																																																																																																																																																																																																																																																																																																																																																																																														
26	2221-35	Upright	1	mm	2650.0																																																																																																																																																																																																																																																																																																																																																																																														
27	2221-36	Upright	1	mm	2650.0																																																																																																																																																																																																																																																																																																																																																																																														
28	2221-37	Upright	1	mm	2650.0																																																																																																																																																																																																																																																																																																																																																																																														
29	2221-38	Upright	1	mm	2650.0																																																																																																																																																																																																																																																																																																																																																																																														
30	2221-39	Upright	1	mm	2650.0																																																																																																																																																																																																																																																																																																																																																																																														
31	2221-40	Upright	1	mm	2650.0																																																																																																																																																																																																																																																																																																																																																																																														
32	2221-41	Upright	1	mm	2650.0																																																																																																																																																																																																																																																																																																																																																																																														
33	2221-42	Upright	1	mm	2650.0																																																																																																																																																																																																																																																																																																																																																																																														
34	2221-43	Upright	1	mm	2650.0																																																																																																																																																																																																																																																																																																																																																																																														
35	2221-44	Upright	1	mm	2650.0																																																																																																																																																																																																																																																																																																																																																																																														
36	2221-45	Upright	1	mm	2650.0																																																																																																																																																																																																																																																																																																																																																																																														
37	2221-46	Upright	1	mm	2650.0																																																																																																																																																																																																																																																																																																																																																																																														
38	2221-47	Upright	1	mm	2650.0																																																																																																																																																																																																																																																																																																																																																																																														
39	2221-48	Upright	1	mm	2650.0																																																																																																																																																																																																																																																																																																																																																																																														
40	2221-49	Upright	1	mm	2650.0																																																																																																																																																																																																																																																																																																																																																																																														
41	2221-50	Upright	1	mm	2650.0																																																																																																																																																																																																																																																																																																																																																																																														
42	2221-51	Upright	1	mm	2650.0																																																																																																																																																																																																																																																																																																																																																																																														
43	2221-52	Upright	1	mm	2650.0																																																																																																																																																																																																																																																																																																																																																																																														
44	2221-53	Upright	1	mm	2650.0																																																																																																																																																																																																																																																																																																																																																																																														
45	2221-54	Upright	1	mm	2650.0																																																																																																																																																																																																																																																																																																																																																																																														
46	2221-55	Upright	1	mm	2650.0																																																																																																																																																																																																																																																																																																																																																																																														
47	2221-56	Upright	1	mm	2650.0																																																																																																																																																																																																																																																																																																																																																																																														
48	2221-57	Upright	1	mm	2650.0																																																																																																																																																																																																																																																																																																																																																																																														
49	2221-58	Upright	1	mm	2650.0																																																																																																																																																																																																																																																																																																																																																																																														
50	2221-59	Upright	1	mm	2650.0																																																																																																																																																																																																																																																																																																																																																																																														
51	2221-60	Upright	1	mm	2650.0																																																																																																																																																																																																																																																																																																																																																																																														
52	2221-61	Upright	1	mm	2650.0																																																																																																																																																																																																																																																																																																																																																																																														
53	2221-62	Upright	1	mm	2650.0																																																																																																																																																																																																																																																																																																																																																																																														
54	2221-63	Upright	1	mm	2650.0																																																																																																																																																																																																																																																																																																																																																																																														
55	2221-64	Upright	1	mm	2650.0																																																																																																																																																																																																																																																																																																																																																																																														
56	2221-65	Upright	1	mm	2650.0																																																																																																																																																																																																																																																																																																																																																																																														
57	2221-66	Upright	1	mm	2650.0																																																																																																																																																																																																																																																																																																																																																																																														
58	2221-67	Upright	1	mm	2650.0																																																																																																																																																																																																																																																																																																																																																																																														
59	2221-68	Upright	1	mm	2650.0																																																																																																																																																																																																																																																																																																																																																																																														
60	2221-69	Upright	1	mm	2650.0																																																																																																																																																																																																																																																																																																																																																																																														
61	2221-70	Upright	1	mm	2650.0																																																																																																																																																																																																																																																																																																																																																																																														
62	2221-71	Upright	1	mm	2650.0																																																																																																																																																																																																																																																																																																																																																																																														



October 26, 2022

Generated with FrameBuilder-MRD Light Steel Designer, V5.1.3

www.rollforming.co.nz

A 06

Watch Video

2
www.rollforming.co.nz

# Connection Details

## Corner Detail

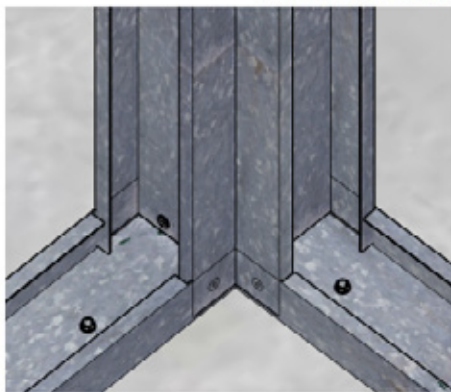
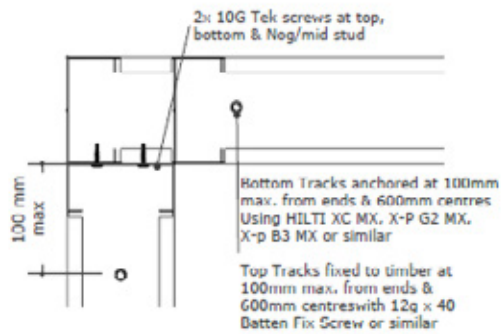

## T Connection Detail

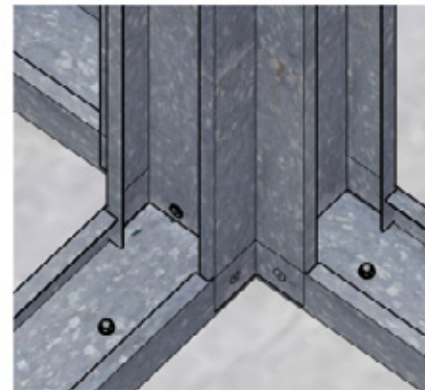
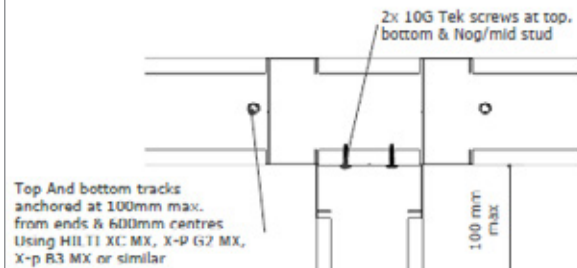

## Door Opening Detail

Top and bottom tracks anchored at 100mm Max. from opening Using HILTI XC MX, X-P G2 MX, X-p B3 MX or similar

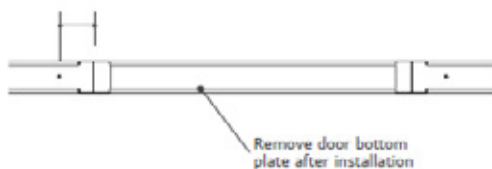

## Panel to Panel Detail

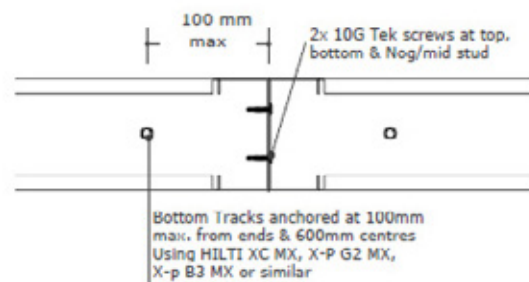

Top Tracks fixed to timber at 100mm max. from ends & 600mm centres with 12g x 40 Batten Fix Screw or similar



# Receiving your made to order panels and assembly plans

Once your order has been manufactured, you will receive your order either partially assembled or flat-packed for an autonomous assembly. Regardless, each order will be despatched with 2 sets of plans:

1. The customised floor plans
2. The customised wall panel assembly plans



## Customised Floor Plans

These plans provide the locational layout of the panel systems over the full site build drawings and the specific directions each individual wall panels are to be installed. It is important to pay particular attention to this plan to install in the correct orientation.

## Customised Wall Panel Assembly Plans

We provide a secondary customised set of plans that detail the wall panel dimensions and their respective orientation of componentry for a clear guide of install methodology.

The use of our numbering system as marked on each physical component matches this plan, making light work of flat-packed assembly anywhere.

Taking the time to preview these plans on receipt and have the customer check them over prior to install is a recommended preliminary step to ensure what has been supplied matches the up-to-date build site requirements.



# Telescopic Panels Designed Installation Steps

## Step 1

Check you have everything supplied by counting the number of physical wall panels against the number of wall panels on your floor plan.

Document Summary

Components

WALLS - 17  
 FLASHING - 8  
 ROOFS - 8  
 TRIMMERS - 8

GENERAL CUSTOM COMPONENTS - 8  
 GENERAL UNGROUPED COMPONENTS - 8  
 TOTAL SCREWS - 476

Notes  
 Longest Length Panel Is - AS - 18 0 - 3888.8 mm

Profile	Flange	Web	Thickness	Storage	Total Weight
60241-15	41.2 mm	82.1 mm	0.75 mm	200.1	200.1
60241-08	41.2 mm	43.8 mm	0.75 mm	68.14	68.62

October 26, 2022  
 Rollforming  
 www.rollforming.co.nz

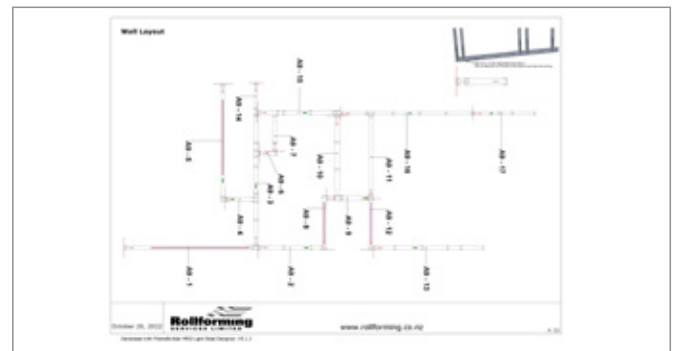

## Step 2

Spend some time unpacking the individually packed components and laying them out in order of installation using the assembly plan so that everything is easily visible and in situ as you go.

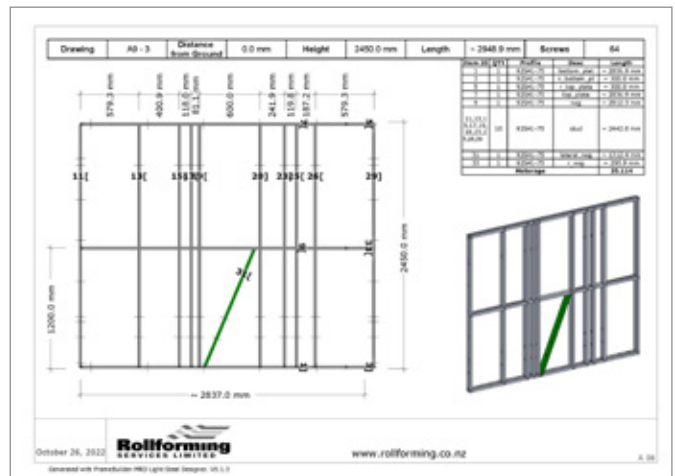

## Step 3

Now take the R Telescopic Stud and the C Stud for all the common studs within the wall panel. Nest the studs web to web. DO NOT BOX the studs.

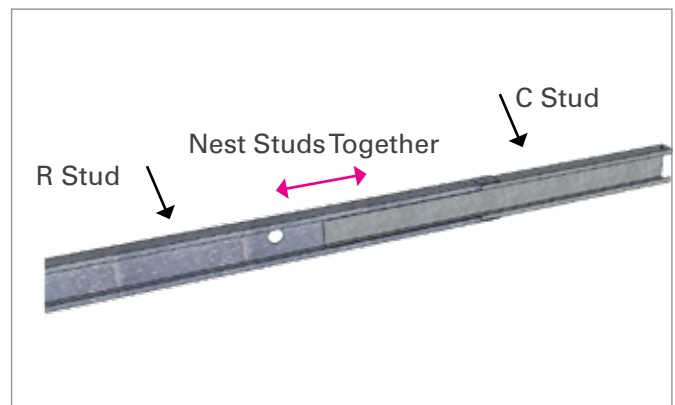

Watch Video

# Telescopic Panels Installation Guide cont

## Step 4

Place the swaged end of the nested C Stud into the floor base track from step 1. Align each C Stud up with the pre-punched locations as per the wall assembly plan. Check to make sure the studs are positioned correctly. Open facing sides should all be in the same direction.

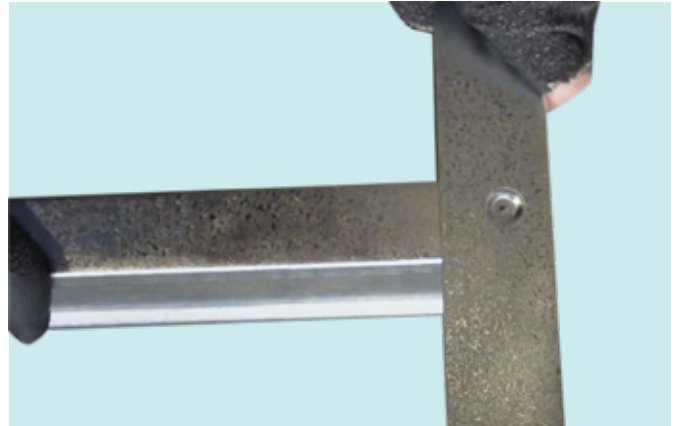

## Step 5

Slot the nogging tracks into the steel studs and align into position flush with the dimples

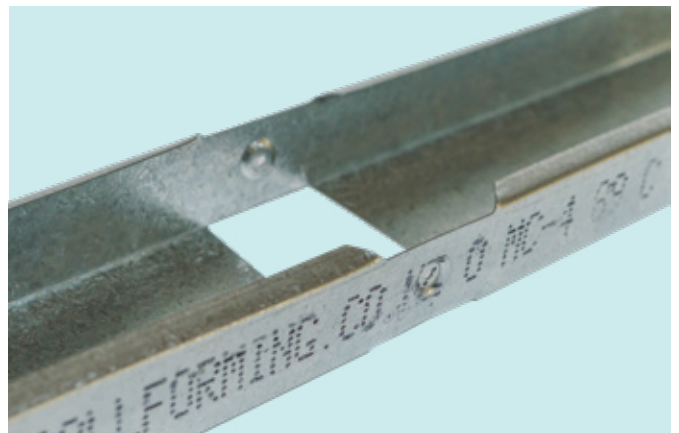

## Step 6

Connect the top slotted deflection head track onto the R Telescopic Stud



## Step 7

Take a minute to check all the connecting points are fitting correctly and are fitted with the 10G framing screw. Check with Rollforming Services the recommended screw specification for best suited to the installation environment. Most NZ climates call for zinc plated coating to protect from any internal moisture



# Telescopic Panels Installation Guide cont

## Step 8

Flip the completed wall panel over to check all connection points on the opposite side are screwed off.



## Step 9

Align the wall frame with the floor set out position correctly and anchor it with the appropriate fixings.



## Step 10

Slide the RTelescopic Studs upward by pushing the head track and moving the top section upward telescopically until it meets the underside of the wall or ceiling above. Align the wall panel to the set out and check the wall panel is not skewed. Now take the approved fasteners and fix the head track into place at no more than 600mm centres.



## Step 11

We recommend #10G wafer head self-drilling screws to fix the RTelescopic Studs and C Studs together. See diagram below. Some methods may vary depending on wall lining conditions. If the splice location is unlined on the wall, secure the two studs together using 4/#10G located in the most upper and bottom holes.

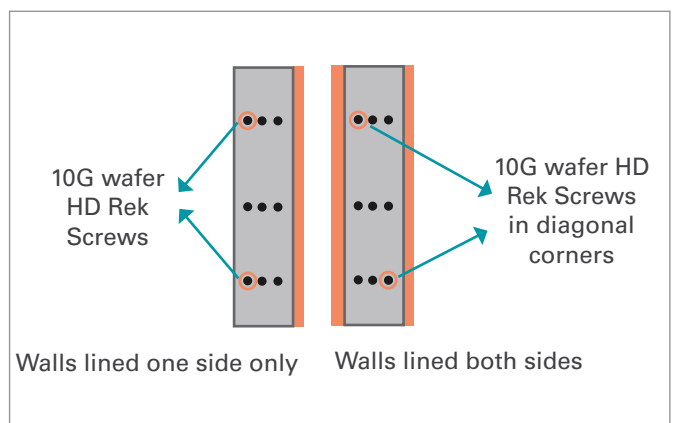

## Standards and Building Codes

Rollforming Services Ltd uses the following standards in its procurement, manufacturing, testing, design and marketing policies for compliance with the respective Building Codes of Australia and New Zealand

Design Standards:

AS/NZS1170 Part 0

Structural design actions- General Principals

AS/NZS1170 Part 1

Structural design actions – Permanent imposed and other actions

AS/NZS1170 Part 2

Structural design actions – Wind actions

AS/NZS1170 Part 4

Structural design actions – Earthquake actions in Australia

NZS/1170 Part 5

Structural design actions – Earthquake actions in New Zealand

AS/NZS4600

Cold-formed steel structures

Steel is purchased to the following standard:

AS1397

Continuous hot-dip metallic coated steel sheet and strip – coatings of zinc and zinc alloyed with aluminium and magnesium

Quality Assurance

ISO 9001

Quality Management Systems

Disclaimer:

Original manufacturer Rollforming Services recommends its products and systems are installed by a qualified tradesperson and according to the relevant codes and standards. Before acting on any advice or opinion in this manual, you should seek professional advice in light of unique architectural and building requirements.

Fire rating of framing to be confirmed by lining board manufacturer.

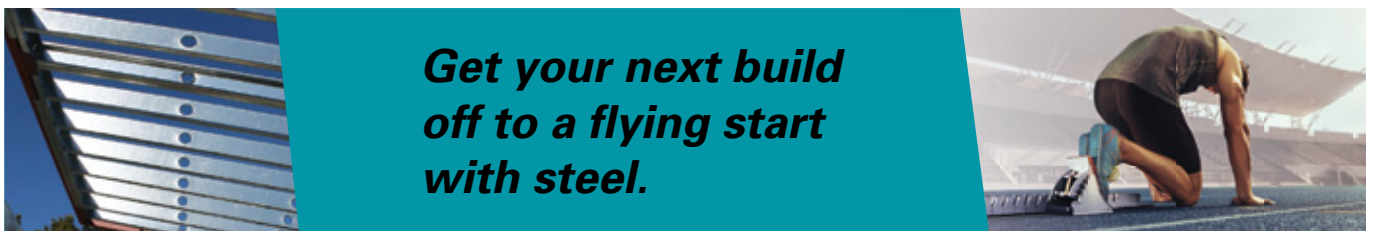

***Get your next build  
off to a flying start  
with steel.***



# Helpful online how to videos

Rollforming Services Telescopic Panel Systems

[Watch Video](#)

## Configurations

Soffit Panels

[Watch Video](#)

Multi-Axis Expanding Panels

[Watch Video](#)

Two-Axis Expanding Panels

[Watch Video](#)

3x3 Kitset Telescopic Panels

[Watch Video](#)

Kitset Telescopic Panels Installation Steps

[Watch Video](#)

Telescopic Panels - Designed

[Watch Video](#)

